

Output power:	5200 - 42000 Watts	Typical applications:	
DC current:	1300 - 3000 A (max. 3000 A / 12 V)	Chrome plating	Barrel plating
DC voltage:	4 - 30 V (max. 1000V / 42 A)	Anodizing/Aluminium colouring	Rack plating

DC power supply with switch mode technology, designed for use in electroplating and/or for installation in a cabinet.



POWER STATION pe3000-9, front view



POWER STATION pe3000-9, back view

Characteristic values

Linearity inaccuracy:

- for amperage < 1 %
- for voltage < 0.5 %

Ripple less than < 2 %

Efficiency typical > 85 %

Powerfactor $\cos \varphi$ 0,95

Constant current and voltage control

Soft start function

Over temperature protection

Internal shunt with 60 mV at I_{nenn}

Pulse operation optional

Mains supply: standard 3 x 400 V +/- 10 % / 50 or 60 Hz without N (other voltages on request)

Cooling

Optimized cooling air guiding, air consumption max. 1000m³/h

Cooling air outlet at DC bus bars

Ambient temperature 35°C (other on request)

Design

Stainless steel casing, optional coated, protection grade IP20

DC connection via screw terminals or tin plated copper bus bars

High voltage proof DC terminals (above 60 V)

EMV: EN50011 class A, group B ; EN61000-6-4 and EN61000-6-2;
CE-conformity low voltage guide line: EN50178

Values	Standard sizes – DC output ¹										other sizes on request	
	3000 A						2500 A	2000 A		1600 A	1300 A	42 A
DC current												
DC voltage	4 V	5 V	6 V	8 V	10 V	12 V	15 V	18 V	20 V	24 V	30 V	1000 V
Mains supply	3 x 400 V AC											
Weight	approx. 111 kg											

Standard dimensions

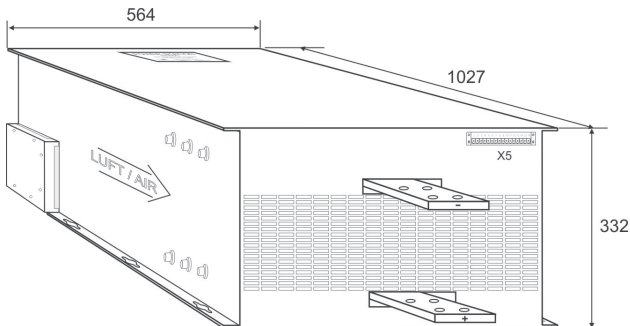

POWER STATION pe3000-9, front view

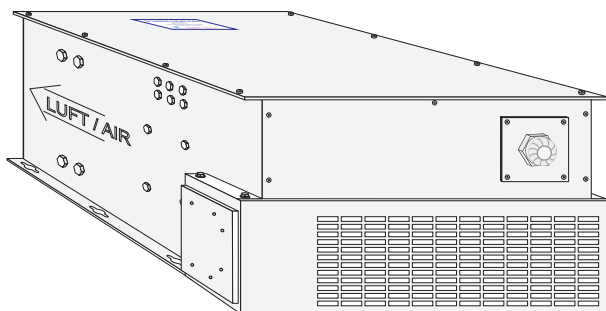

POWER STATION pe3000-9, back view

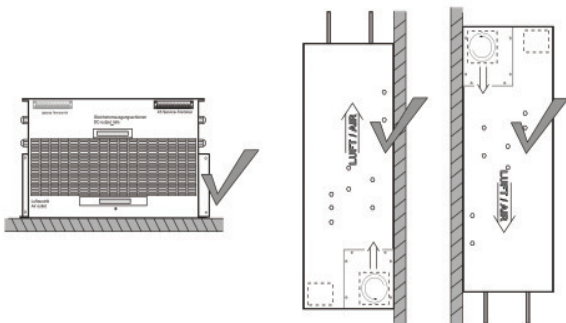

Allowed position of the rectifier module

Control

Standard: peRB-interface

Optional: external control via analog signals, also with integrated isolation amplifier

Signals: 0-10V
0-1V
4-20mA
0-20mA (other on request)

Control unit pe280 for the controlling of DC power supplies of the series POWER STATION pe3000

Designed for electroplating applications

Large 3-line LCD-display, polycarbonate-keypad for easy operation

Current and voltage infinitely adjustable by UP / DOWN buttons

Current and voltage preset

Ampere-hour counter (totalizer)

Protection grade: IP54

Ambient temperature max. 40°C



Optional available functions

Preset counter, dosage counter *

Ramp function (start / stop ramp)

Timer function for ON / OFF *

Voltage / current alarm *

Operating hours counter

Chopper timer (pulse-capable rectifier type requested)

Pole changer function (mechanical / electronic) *

Programmable DC steps (14 individual steps) *

Extern ON

* Indication / alarm output

Control via: RS485, PROFIBUS, TCP/IP (other on request)

Technical equipment, design and features: subject to change! For further information please contact plating electronic GmbH.