

- **Economic**
- **Functional**
- **Sustainable**

400 - 1.800 l/h Cartridge filter

Typical applications

Plating, processes and laboratories

Features

- Magnetic drive pump
- Filter chamber with welded bottom (no seal)
- PP construction, non-metallic solution contact
- EPDM elastomers
- Cartridge tightened by knob, no by-pass
- Air release valve
- Drain valve
- Max. temperature 70°C
- Hose connection, in & outlet same diameter
- Single phase motor with thermal protection
- On/Off switch IP55 and cable included



Bofil-11K-1200



Bofil-12K-1800

Filter Systems 1K Bofil Series

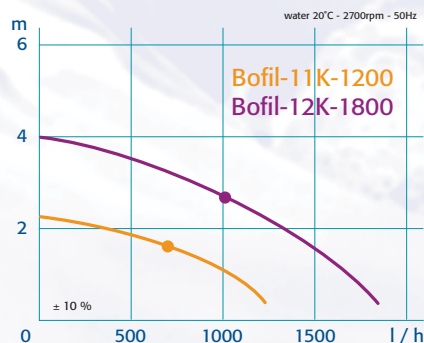

Type	Flow	Head	Filter	Connections		Motor (50Hz)				
	max (l/h)	max (m)	Cartridge	In	Out	Watt	Phase	Voltage	Amp	RPM
Bofil-11K-1200	1000	2,1	1 x 10"	18 mm hose		45	1	200~240	0,20	2700
Bofil-12K-1800	1600	4,0	1 x 20"	20 mm hose		110	1	200~240	0,35	2700

Bofil-11K-1200

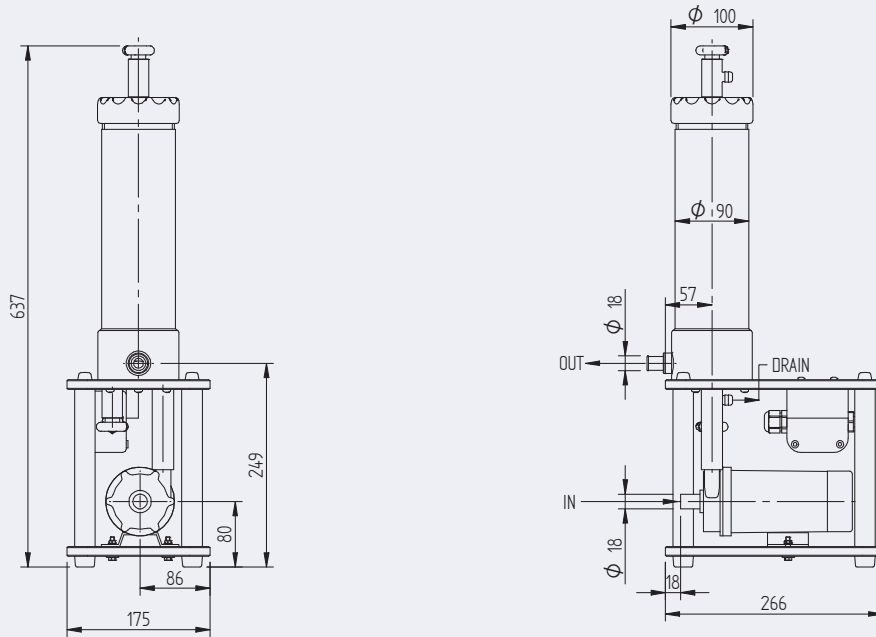

Bofil-12K-1800

